

Kincaid Performance Inc.

Installation instructions for 1999-2004 Ford Lightning

Killer Chiller parts inventory. Please check and confirm all parts are present with your Killer Chiller kit.

- Killer Chiller
- Coolant hose
- A/C hose
- A/C condenser/liquid line fittings bag
 - 1 - 90 degree male SAE fitting
 - 1 - straight female SAE fitting
 - 2 - cages
 - 4 - retainers
- Killer Chiller A/C fittings bag
 - 2 - JIC female swivel fittings
 - 2 - cages
 - 4 - retainers
- Killer Chiller coolant line fittings
 - 2 - 90 degree elbows
 - 6 - hose clamps
 - 1 - metal strap
 - 2 - self tapping screws
 - 2 - washers for self tapping screws

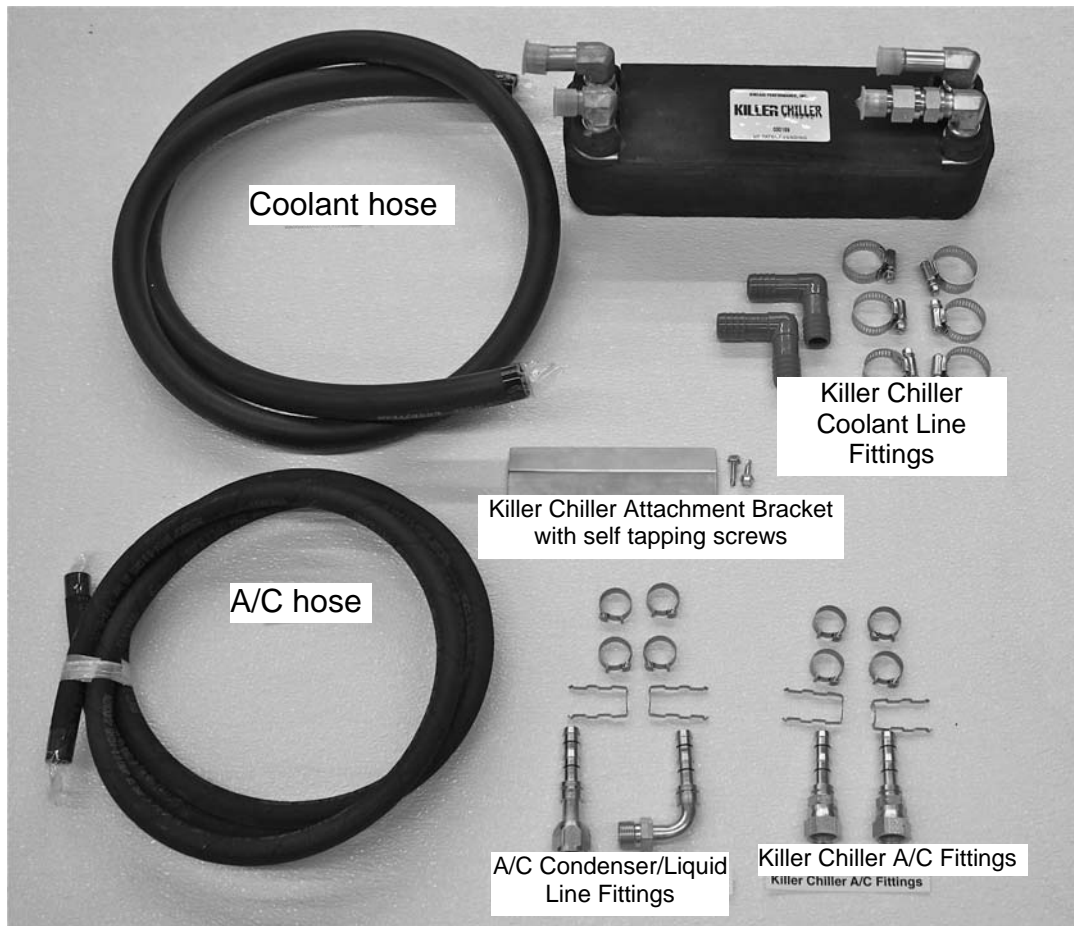

Special
tools
Needed:

Hose cutter (Any auto or hardware store)

Concrete nippers (also called end cutters) (Any hardware store will have these; about \$12.00)

Small can of PAG oil (Auto parts store in the A/C section)

Optional:

Panel fastener removal tools



at (850) 292-9987 or Joe at (505) 275-2665

For assistance please call Danny

Lets get started!

Discharge A/C system.

Jack front of vehicle and place on jackstands.

1. Remove intercooler reservoir cap.



2. Open drain on bottom of heat exchanger and drain coolant.

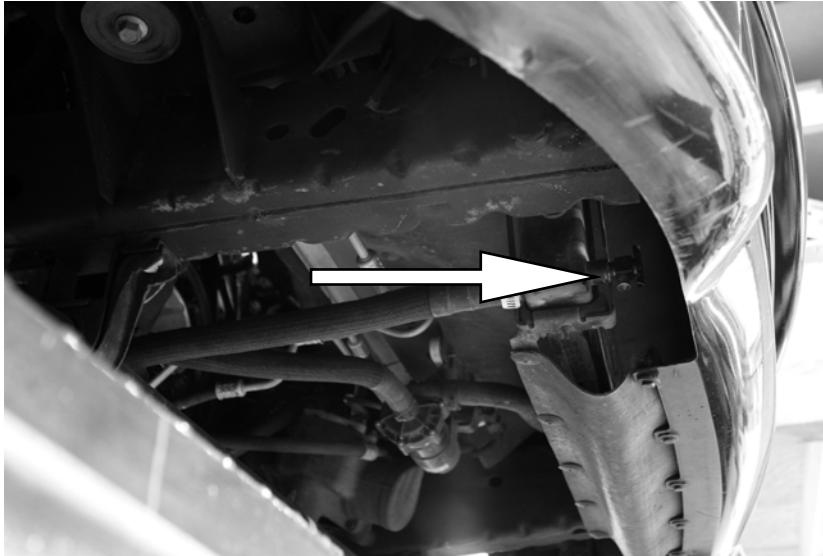

3. Remove both coolant lines from heat exchanger.

NOTE: To ease disconnecting the IC pump hose, disconnect at the pump instead of at the heat exchanger.



4. Remove the two 8mm bolts securing the heat exchanger.

5. Remove the heat exchanger.

6. Remove the rubber shield that runs from the core support to bumper reinforcement. A panel fastener tool is helpful here.

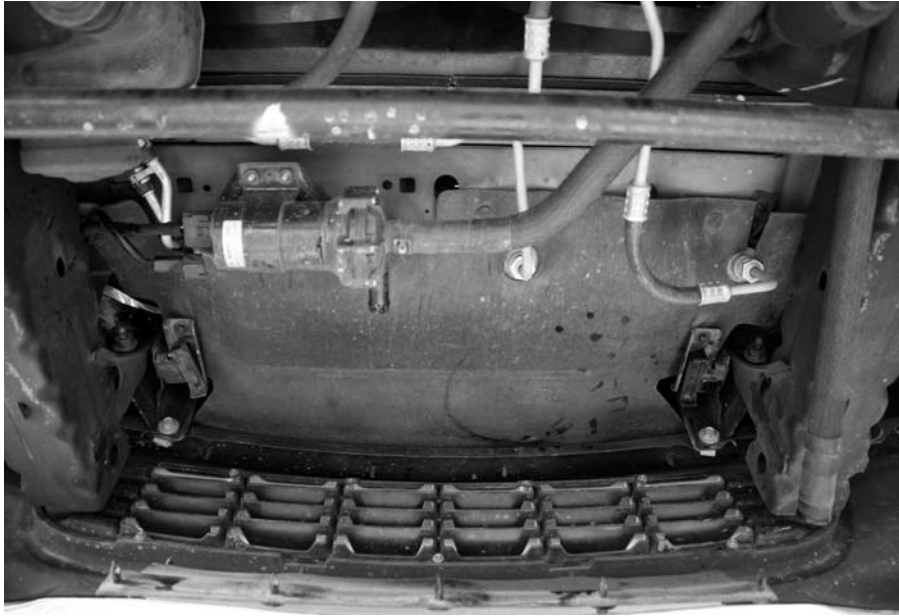

7. Slide the KC core into the center of the bumper reinforcement. The core will be directly behind the bumper and will fit snugly between the bumper and turned edges on the bumper reinforcement.

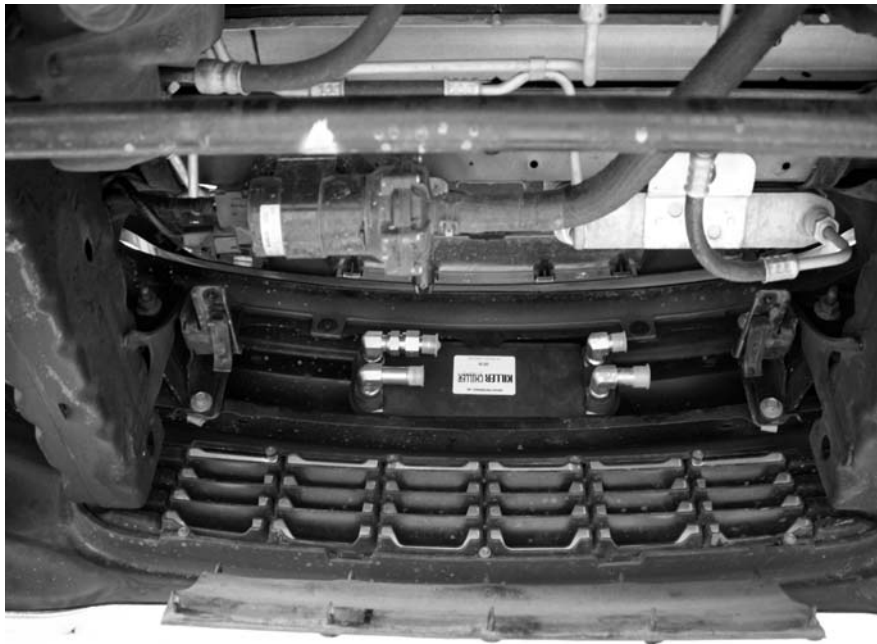

reinforcement at top and bottom with supplied self tapping screws.

8. Place the supplied metal strap over the KC core and attach to bumper

This picture already has the A/C lines installed but is shown for reference for the location of the metal strap.

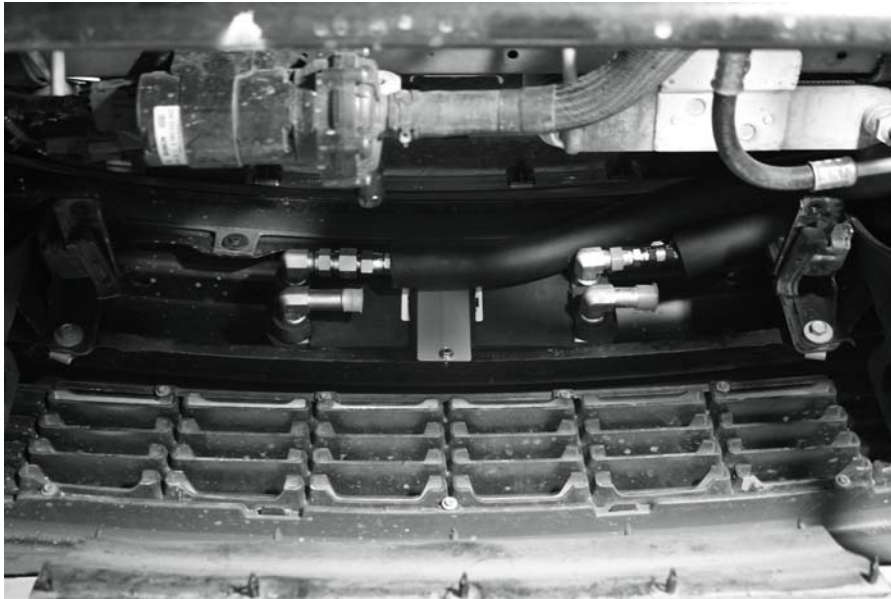

9. On the passenger side of the vehicle find the A/C line that runs from the condenser to the firewall. Towards the condenser side you will find a bolted together connection between the

A/C line and the condenser line. Using two wrenches hold condenser line with one and loosen the A/C line nut with the other (this will keep from twisting line coming out of the condenser)

NOTE: Removing the windshield washer reservoir, battery, and battery tray will provide better access to the A/C line as well as providing more room for routing of the new A/C lines to the KC.

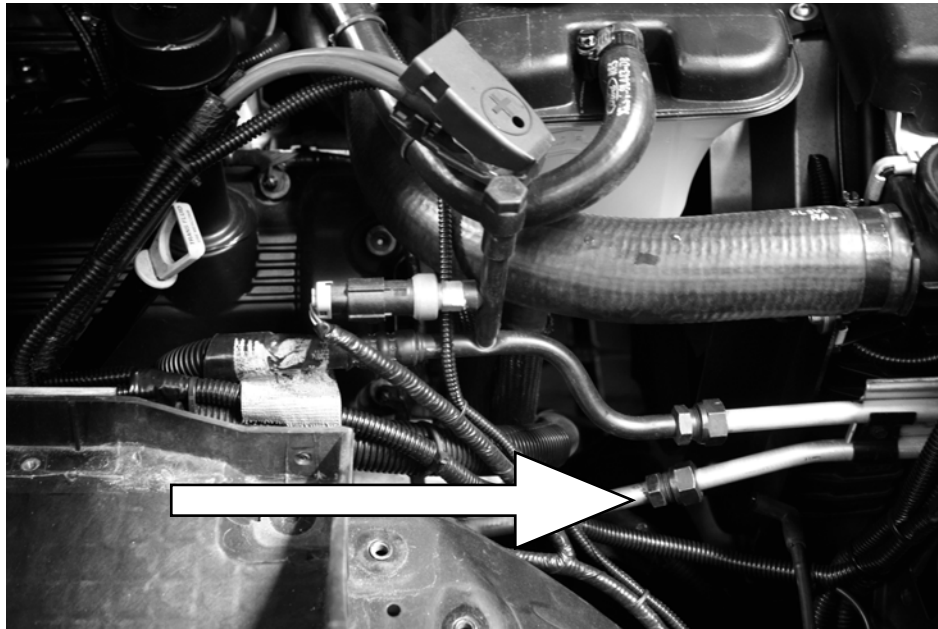

**NOW THIS IS VERY IMPORTANT!
REMOVE THE
FACTORY ORIFICE
TUBE FROM THE
INSIDE THE LINE YOU
JUST UNBOLTED.
JUST TAKE A PAIR OF
NEEDLE NOSE
PLIERS AND PULL IT**

STRAIGHT OUT OF THE LINE. (IT IS A BLUE PLASTIC LOOKING THING)

Photo showing the orifice tube partially removed from the A/C line.

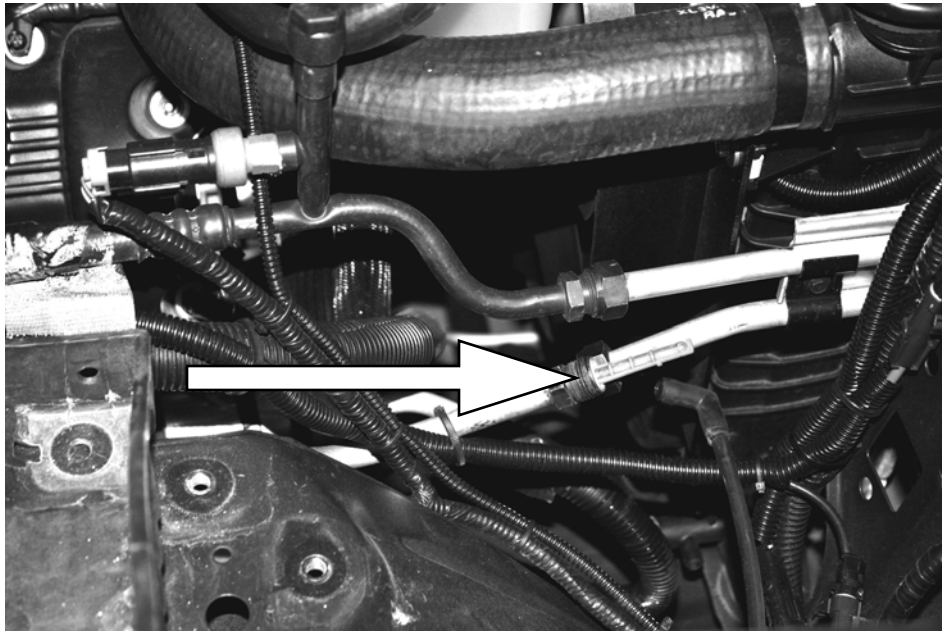

NOTE: Use PAG oil on all A/C fittings, this will make it easier to push the A/C hose onto the fittings.

11. In the Killer Chiller A/C condenser/liquid line fitting bag you will find a 90 degree male SAE fitting and a straight female SAE fitting with an O-ring. Measure and cut a section of A/C hose (supplied with the kit) from the condenser side of the line, (female end) to the male A/C fitting with the orifice tube on the KC core, then slide the hose onto the male 90 degree SAE fitting. (Use PAG oil to lubricate) Install the cage and two retainers. (use the concrete nippers to install the retainers) Now bolt the 90 degree male SAE fitting to the female end of the condenser line.

NOTE: Picture shows both A/C lines connected with new hardware and insulated.

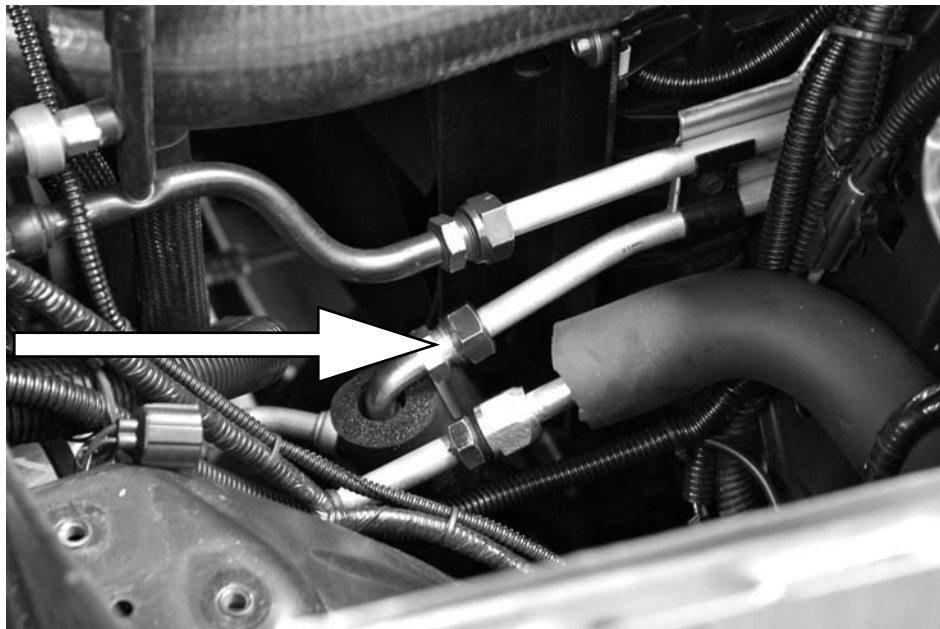

12. Install the JIC female swivel fitting (located in the Killer Chiller A/C fittings bag) to the other end of this A/C hose (using the supplied cage and

retainers) and screw it into the male fitting with the orifice tube on the KC core.

13. Repeat the same process with the female SAE O-ring fitting by attaching it to the A/C side of the line, and back to the other male fitting on the KC core using the supplied JIC female swivel fitting.

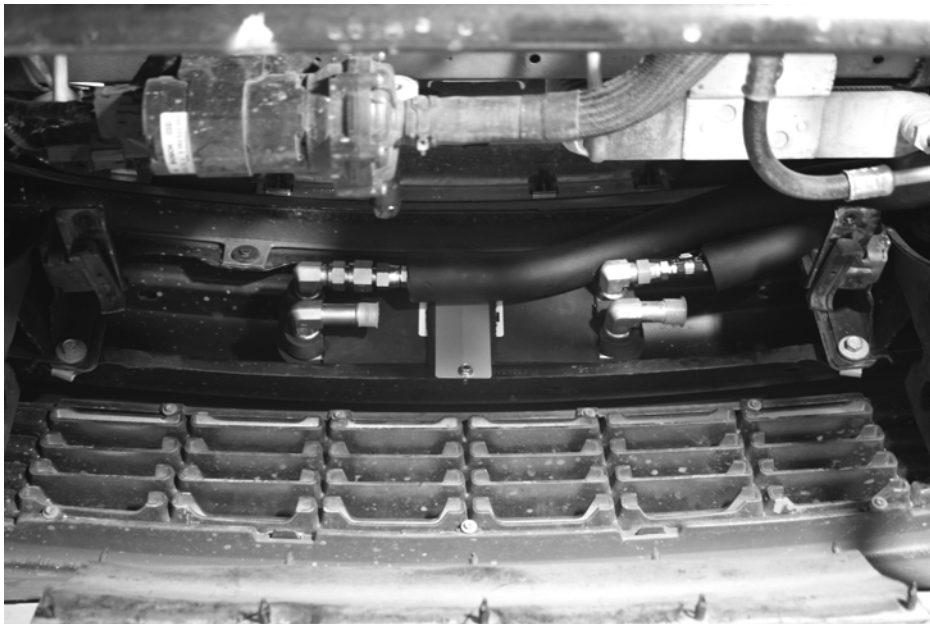
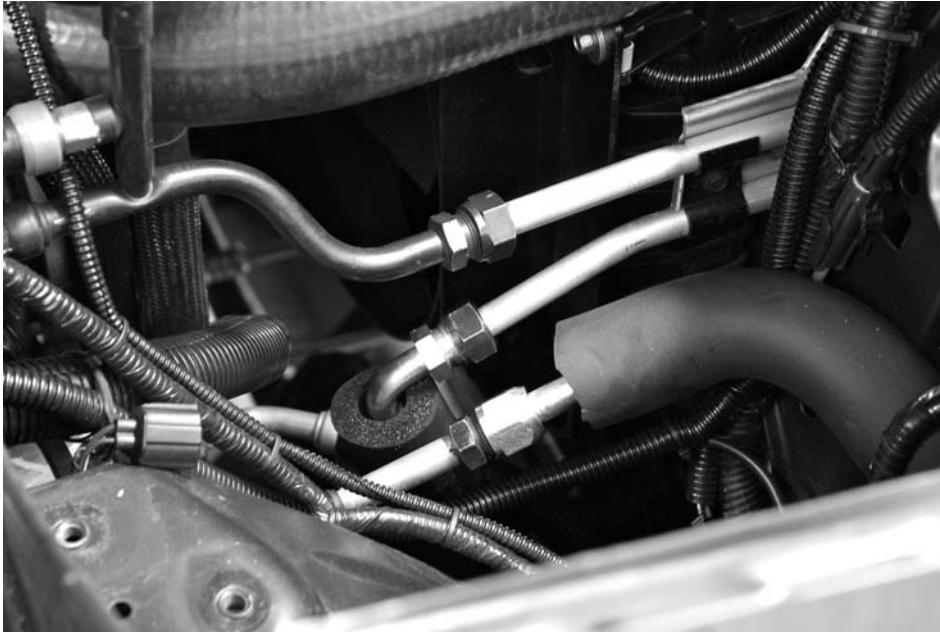

This photo shows both A/C lines connected to the KC core.

heat exchanger back into brackets. (for fitting reasons)

14. Temporarily set

15. Install the supplied $\frac{3}{4}$ inch elbow into the stock coolant line that was removed from the passenger side of the heat exchanger. Clamp with supplied hose clamp.

16. Install supplied $\frac{3}{4}$ inch heater hose to other side of elbow. Clamp with supplied hose clamp.

17. Route hose to the passenger side of KC and cut as needed and install using supplied hose clamp.



Photo showing steps 15, 16, and 17 completed.

18. Install rest of the heater hose into the drivers' side of the KC.

19. Route hose back to the passenger side of the heat exchanger and cut as needed.

20. Install supplied $\frac{3}{4}$ inch elbow and clamp with hose clamp.

21. Cut the remainder of the hose to a length of 4 inches.

22. Install the 4 inch hose on the other side of the elbow and clamp with hose clamp.

NOTE: The other side of the 4 inch hose will be installed to the passenger side of the heat exchanger once permanently installed.



Photo showing steps 18, 19, 20, 21, and 22 completed.

23. Remove heat exchanger.

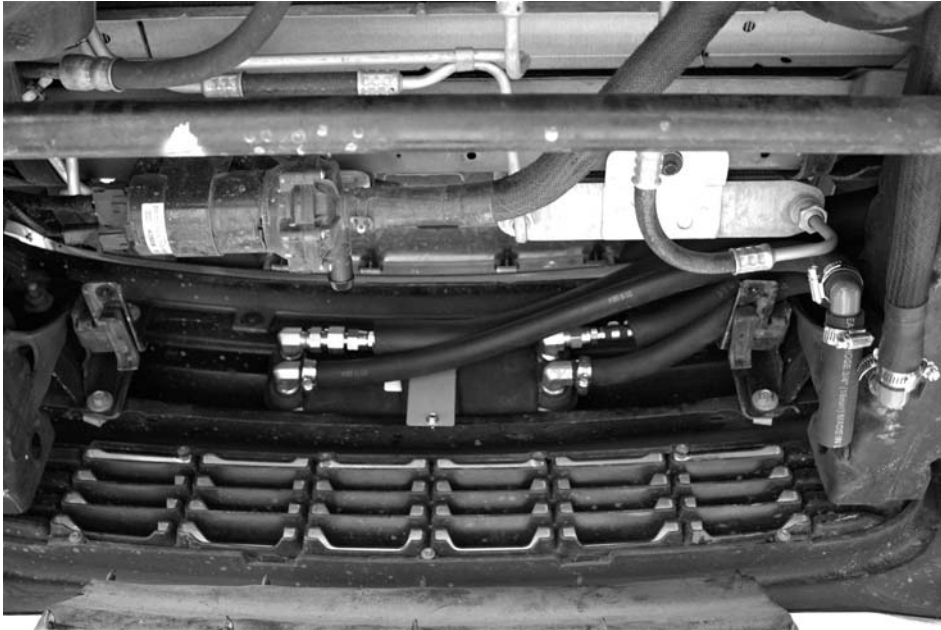

Photo showing heat exchanger removed with all KC lines connected.

CAUTION! Double check hose clamps on coolant lines and A/C fittings on KC for tightness before the final installation of the rubber shield.

24. Trim the previously removed rubber shield for fitment around the bracket for KC and hoses as necessary and then reinstall.



Photo showing initial trimming for the KC.

Additional trimming may be needed on the passenger side to accommodate coolant hose routing.



Rubber shield installed.

exchanger

25. Install heat

26. Reinstall coolant lines to heat exchanger



Photo showing steps 25 and 26 completed.

windshield washer reservoir were removed earlier reinstall them now

27. Fill intercooler system with desired mixture of coolant and distilled water

27. If battery tray, battery, and

Congratulations! You have finished the Killer Chiller install!

Have A/C system evacuated and charged with R134a refrigerant. (Prior to installing refrigerant, mechanic should install approximately two ounces of PAG oil to lubricate new hoses.)

Take the outside temperature and multiply it by 2.5. This is approximately what your high side pressure should be once your A/C is charged properly

For the temperature gauge sender unit: Drill a hole into the bottom side of the intercooler reservoir and thread sender into the hole. (Use silicone for water tight seal)